

Description:

Engine type	TW 110 G5V TX 86	
Fuel	wood gas	
Engine design	stationary	
Engine working cycle	four-stroke, spark ignited	
Design	in-line, vertical	
Number of cylinder	6	
Valve train	OHV	
Number of valves per cylinder	2	
Turbocharging	yes	
Intercooler	no	
Mixture	stoichiometric	
Cooling	liquid	
Operation (looking at flywheel)	anticlockwise	
Displacement	11,946	[dm ³]
Bore	130	[mm]
Stroke	150	[mm]
Compression ratio	9,5:1	[-]
Firing order	1-5-3-6-2-4	[-]

Rated parameters at reference conditions:

Rated speed	1500	[rpm]
Rated power output (continuous)	111	[kW]
Peak torque	707	[Nm]

Engine heat output:

Coolant heat output	119,6	[kW]
Exhaust gas heat output (cooled to 150 °C)	71,9	[kW]
Radiation heat power	13,0	[kW]

Parameters under load:

Load	100	75	50	25	[%]
Fuel input power	336,4	282,2	231,3	164,2	[kW]
Efficiency	33,0	29,5	24,0	16,9	[%]
Fuel consumption	231,1	193,9	158,9	112,8	[m ³ .h ⁻¹]

Load Characteristics:

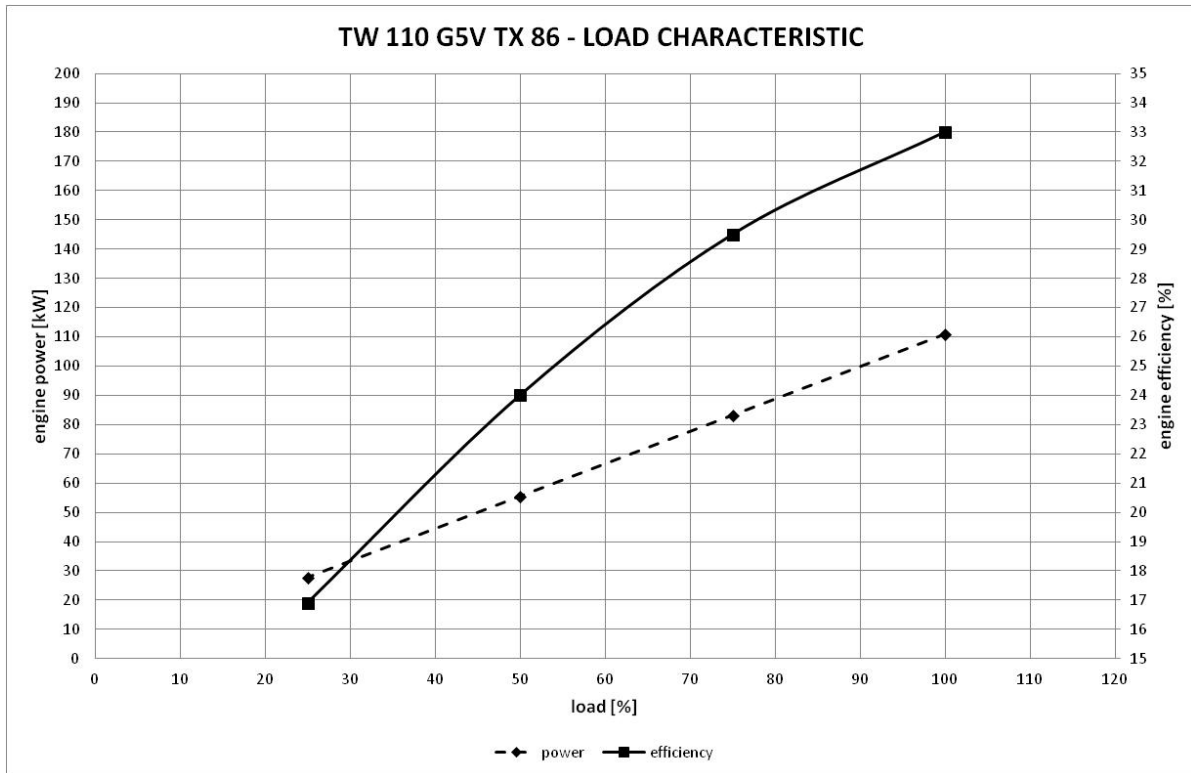

Tolerance values given in the specification is subject to internal regulation TEDOM: 61-0-0284.

Engine parameters and settings:

Ignition advance	-	[°]
Coefficient of excess air λ	1	[-]
Exhaust gas temperature at the inlet to the turbocharger	650	[°C]
Exhaust gas temperature at the outlet from the turbocharger	580	[°C]
Combustion air flow	326	[kg.h ⁻¹]
Exhaust gas flow	557	[kg.h ⁻¹]
Max. exhaust back pressure for rated parameters (at output of the turbocharger)	3,5	[kPa]
Recommended exhaust gas temperature for warning signal (before turbocharger)	690	[°C]
Recommended exhaust gas temperature for stop signal (before turbocharger)	700	[°C]

Technical and build-up parameters:

REGIME OF THE ENGINE REVOLUTION		
Overrun speed max. - gas cut-off	2100	[rpm]
Overrun speed max. - ignition deactivation	2100	[rpm]
ENGINE LUBRICATION		
Lubricating oil - total	56	[dm ³]
Lubricating oil - oil sump - max. mark	51	[dm ³]
Lubricating oil - between max. and min.	10	[dm ³]
Oil consumption	0,3-0,5	[g.kW ⁻¹ .h ⁻¹]
Min. operating oil pressure (rated speed)	360	[kPag]
ENGINE COOLING		
Volume of coolant in engine	22	[dm ³]
Coolant temperature at the outlet from the engine	85-95	[°C]
Max. coolant temperature short time (1 hour)	100	[°C]
Min. coolant temperature for 100 % load	60	[°C]
Maximum load for the coolant temperature below 60 °C	25	[%]
Minimum coolant temperature for start	10	[°C]
Recommended power cooler	200	[kW]
Required engine coolant flow	250-300	[dm ³ .min ⁻¹]
Maximum cooling circuit pressure	260	[kPaa]
OPERATING LIMITATIONS		
Min. intake air temperature for start	10	[°C]
Intake air (mixture) temperature input before turbocharger for the nominal parameters	25	[°C]
Maximum temperature of the engine compartment during operation	60	[°C]
Allowed crankcase pressure range	-1,5/+1	[kPa]
OPERATING CLEARANCE		
Cold valve clearance - intake valve	0,30	[mm]
Cold valve clearance - exhaust valve	0,55	[mm]

Emissions:

Nitrogen oxides - NO _x	<1000	[mg.m _n ⁻³]
Carbon monoxide - CO	< 2000	[mg.m _n ⁻³]
Total hydrocarbons - HC	-	[mg.m _n ⁻³]
Particulate - PM ^b	-	[mg.m _n ⁻³]
Formaldehyde - HCHO	-	[mg.m _n ⁻³]

Engine noise:

Sound pressure level	91	[dB(A)]
----------------------	----	---------

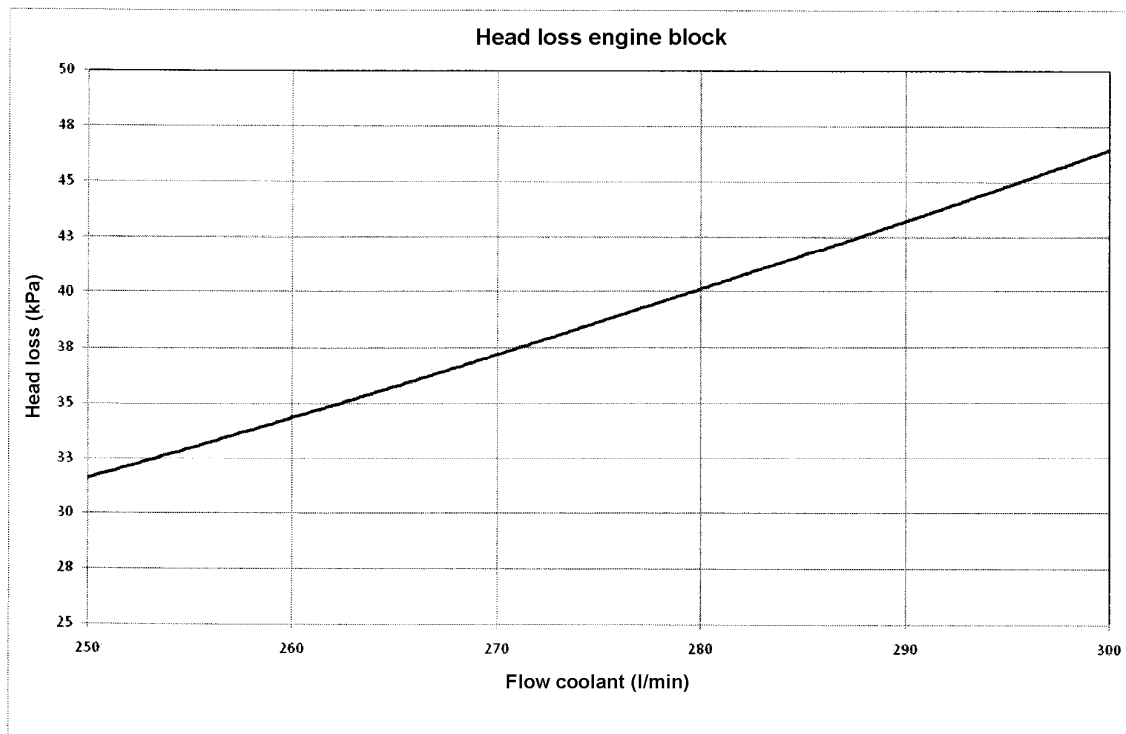
Head loss engine block:

Reference ambient conditions:

Barometric pressure	100	[kPa]
Ambient temperature	25	[°C]
Relative air humidity	30	[%]

Fuel characteristic for rated parameters:

Fuel pressure - reference	101,325	[kPa]
Fuel temperature - reference	0	[°C]
Fuel relative humidity	0	[%]
LHV	5,24	[MJ.m _n ⁻³]
CH ₄ concentration (biogas engines)	-	[%]
CO ₂ concentration (biogas engines)	-	[%]

Allowed fuel characteristic:

Fuel efficiency (biogas engines)	5 – 6	[MJ.m _n ⁻³]
Minimum CH ₄ concentration	-	[%]
Minimum methane number fuel	20	[-]
Maximum fuel moisture	35	[%]
Maximum fuel temperature	35	[°C]

Correction of power depending on the altitude:

Altitude	500	750	1000	1250	1500	[m a.s.l.]
Correction factor	1	0,95	0,90	0,86	0,81	[-]

Correction of power depending on the temperature of inlet air:

Inlet air temperature	0	5	10	15	20	25	30	35	40	45	50	[°C]
Correction factor	1,18	1,14	1,11	1,07	1,04	1	0,96	0,93	0,89	0,86	0,82	[-]

Time limits for low load operation:

Engine power [%]	Runtime [min]
0 – 30	30*
31 - 50	120*
51 - 100	Continuous

* After allowed running time under 51 % of nominal power must follow min. 2 hours recovery run above 70 % of nominal engine power.

Other operating restrictions:

- Up to 4 Start per day are possible
- Minimum runtime 1 hour per Start
- Due to wear 1 start is equal 0,5 operating hours

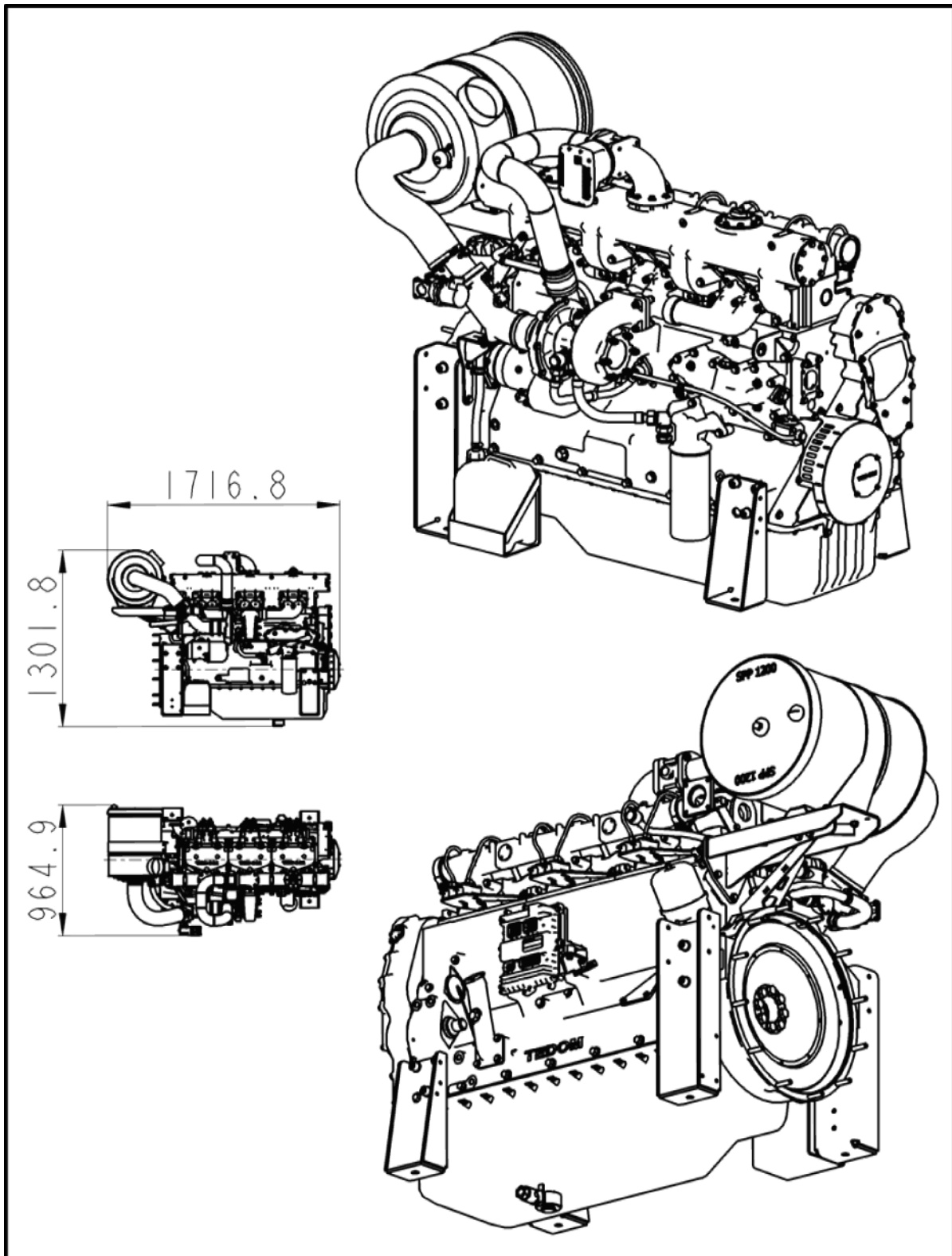
Outline dimensions of the engine:

Total engine weight:

Total engine weight	950	[kg]
---------------------	-----	------

Fitting dimensions of the engine:

Flywheel housing	SAE 1 (alternator)
Engine block/ flywheel housing	SAE 1 (with rear brackets)
Engine block	4 x M16 (for front brackets)
Flywheel	SAE 11½ (or SAE 14)

Scope of supply:

According to customer request

Publication specification:

Date of specification:	Specification version:	Elaborated by:	Note:
17.7.2013	1st. edition	T. Hampl	
27.3.2019	REVISION A	V. Gulova	Revision No. 520/19
28.4.2020	REVISION B	V. Gulova	Revision No. 534/20
9.4.2021	REVISION C	V. Gulova	Revision No. 535/21
	REVISION D		