

ZT-3400[®]

UNMATCHED MANEUVERABILITY

- ⚙️ Designed for mid-size commercial vehicles
- ⚙️ High-efficiency 12cc pump & 16cc motor
- ⚙️ Standard shock valves for added system protection
- ⚙️ External oil filter for easy maintenance

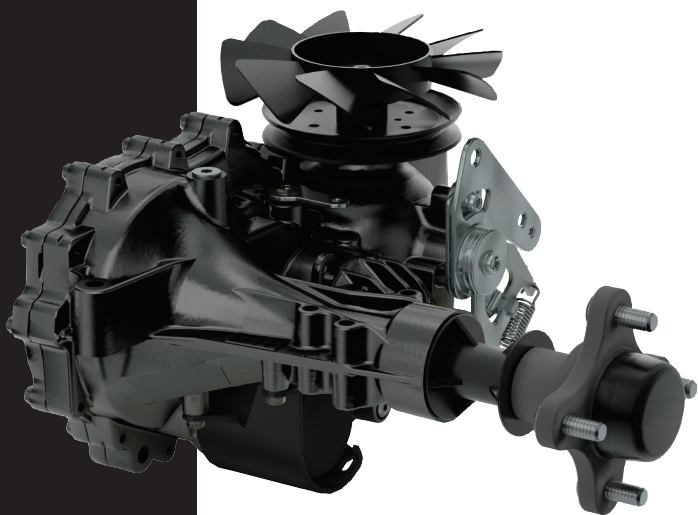

HYDRO-GEAR[®]
COMMERCIAL

DESIGNED & ASSEMBLED IN THE USA

ENGINEERED TO PERFORM

SPECIFICATIONS

Pump Displacement	0.73 in³/rev [12 cc/rev]
Motor Displacement	0.97 in³/rev [16 cc/rev]
Input Speeds	
Max Hi-idle (No Load)	3600 rpm
Min (Loaded)	1800 rpm
Output Torque	up to 500 lb-ft [up to 677 Nm]
Speed	up to 10 mph [up to 16 kph]
Gross Vehicle Weight	up to 1600 lbs [up to 725 kg]
Axle Shaft Diameter	1.125 in [28.56 mm]
Axle Shaft Options	Tapered 4 or 5 bolt Flange
Weight of Unit	34.5 lbs [15.6 kg]

Specifications subject to change without notice

**FOR MORE INFORMATION VISIT:
WWW.HYDRO-GEAR.COM**



ZT3400-10/2017-V1