

Exceptional Power Density and Durability

The heart of the new compact Torqmotor™ is the strongest drive train in its class. Coupled with this extra heavy-duty drive train are the high efficiencies and low speed performance for which the Parker Torqmotor™ is

known. As with all Torqmotors™, high speed valving and full flow drive train lubrication are standard. Case drains are not required. Roller vanes and a sealed commutator maintain high efficiencies and provide smooth low speed performance.

- **Langsamlaufender Gerotor-Motor**

- **Spezielle Orbital-Steuerung**

Geringe interne Leckage

Hoher volumetrischer Wirkungsgrad

- **Rollen im Rotorsatz**

Reduzierte Reibung

Lange Lebensdauer

- **Patentierter Hochdruckwellendichtung**

Keine Leckölleitung

Keine Rückschlagventile

- **Vielzahl von Varianten**

Großer Einsatzbereich

- **Moteur lent système Gerotor**

- **Une distribution orbitale particulière assure**

fuites internes minimales

rendements volumétriques élevés

- **Le rotor à rouleaux**

réduit les frottements

augmente la durée de vie

- **Par l'utilisation de joints d'arbre haute pression brevetés**

pas de conduite de drainage

pas de clapets anti-retour

- **Grâce à de nombreuses variantes**

larges domaines d'application

- **Low Speed Gerotor Motor**

- **Zero leak commutation valve**

For greater, more consistent

volumetric efficiency

- **Roller vane rotor set**

Reduces friction and internal leakage

Maintaining efficiency throughout the life of the motor

- **A patented high-pressure shaft seal**

No check valves needed

No extra plumbing

- **Wide choice of displacement range, flange and shaft options**

Greater efficiency in systems design to suit your application

- **Motore orbitale a bassa velocità**

- **Una particolare distribuzione orbitale assicura**

trafilamento ridotto

elevato rendimento volumetrico

- **Con lo statore a rullini**

si riduce l'attrito interno

si mantiene nel tempo l'efficienza del motore

- **Una guarnizione di tenuta ad alta pressione brevettata elimina la necessità**

di una linea di drenaggio esterna

e di valvole di non ritorno

- **Un'ampia gamma di cilindrata, flange ed alberi**

consentono scelte adeguate ad

ogni esigenza costruttiva

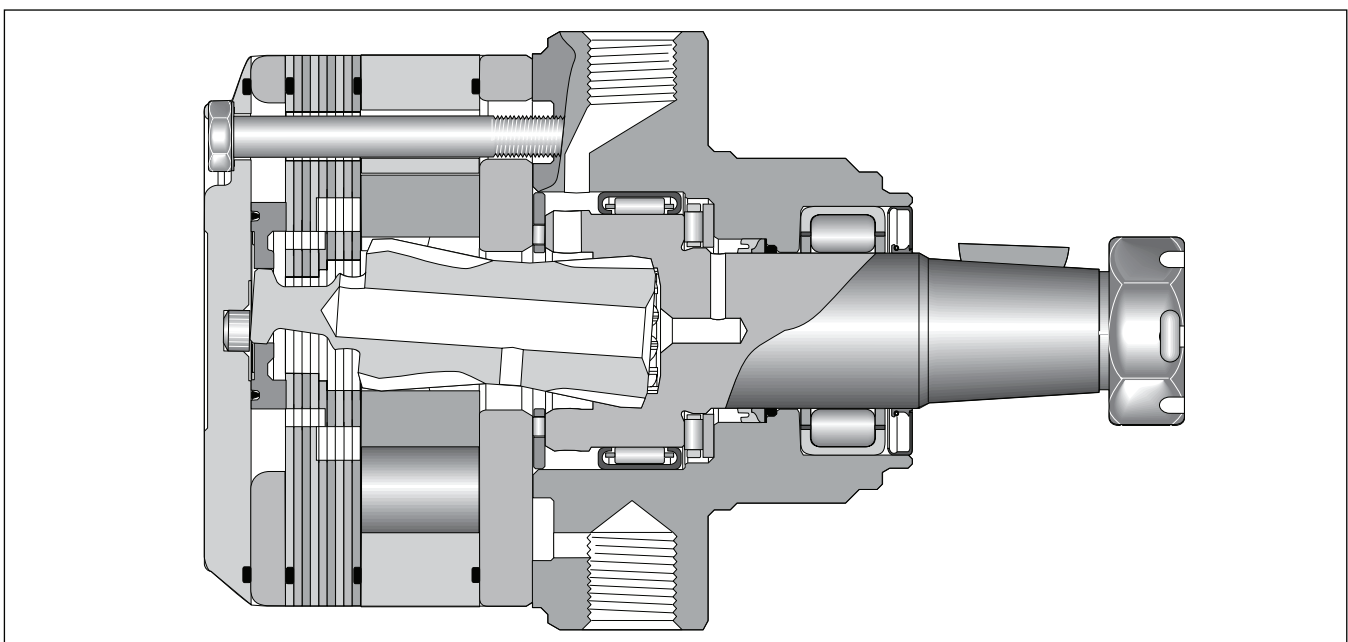

Performance

Drehzahl Speed Vitesse de rotation Velocità di rotazione	max. 613 rev/min
Schluckstrom Oil flow Débit d'huile Portata	max. 95 l/min
Eingangsdruck Supply pressure Pression entrée Pressione in entrata	max. 300 bar
Torque Couple Coppia	max. 1.163 Nm
Seitenlast Side load Charges latérales Carico radiale	max. 16.000 N See page 39

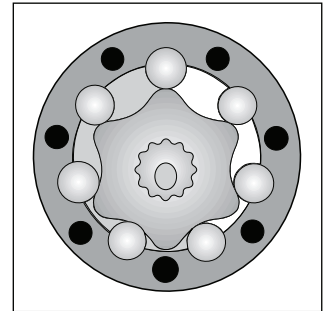
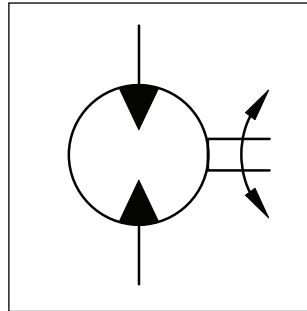

Motor series TL	Geom. Schluckvolumen Geometric displacement Cylindrée Cilindrata	Max. Drehzahl Max. speed Vitesse de rotation maxi Velocità di rotazione max	Max. Schluckstrom Max. oil flow Débit d'huile max Portata max	Max. Druckdifferenz ** Max. differential pressure ** Chute de pression maxi ** Caduta di pressione max **	Max. Eingangsdruck Max. supply pressure Pression maxi entrée Pressione max in entrata	Max. Drehmoment Max. torque Couple maxi Coppia max	Max. Leistungabgabe Max. performance Puissance de sortie maxi Potenza meccanica max	Min. Anlaufmoment Min. starting torque Couple min. fourni au démarrage Coppia min. di spunto
	[cm ³ /U] [cm ³ /rev]	cont / int* [U/min] [rev/min]	cont / int* [l/min]	cont / int* [bar]	max [bar]	cont / int* [Nm]	cont / int* [KW]	cont / int* [Nm]
TL0140	140	613	68/95	190/241	300	364/463	30	294/365
TL0170	169	512	68/95	190/241	300	449/570	31	354/445
TL0195	195	484	68/95	190/241	300	511/648	34	414/526
TL0240	238	399	68/95	190/241	300	620/790	34	536/679
TL0280	280	335	68/95	190/241	300	730/929	34	619/787
TL0310	310	310	68/95	190/241	300	847/1079	36	713/907
TL0360	364	255	68/95	172/224	300	890/1163	31	778/1002

*int. =

Intermittierende Werte maximal: 10% von jeder Betriebsminute.

Intermittent operation rating applies to 10% of every minute.

Fonctionnement interm.: 10% max. de chaque minute d'utilisation.

Servizio intermittente: 10% max di ogni minuto di utilizzazione.

** Druckdifferenz Δp zwischen Ein- und Ausgang

** Pressure difference is Δp between input and output

** La différence de pression est Δp entre l'entrée et la sortie

** La differenza di pressione corrisponde al Δp tra ingresso e uscita

Code: L

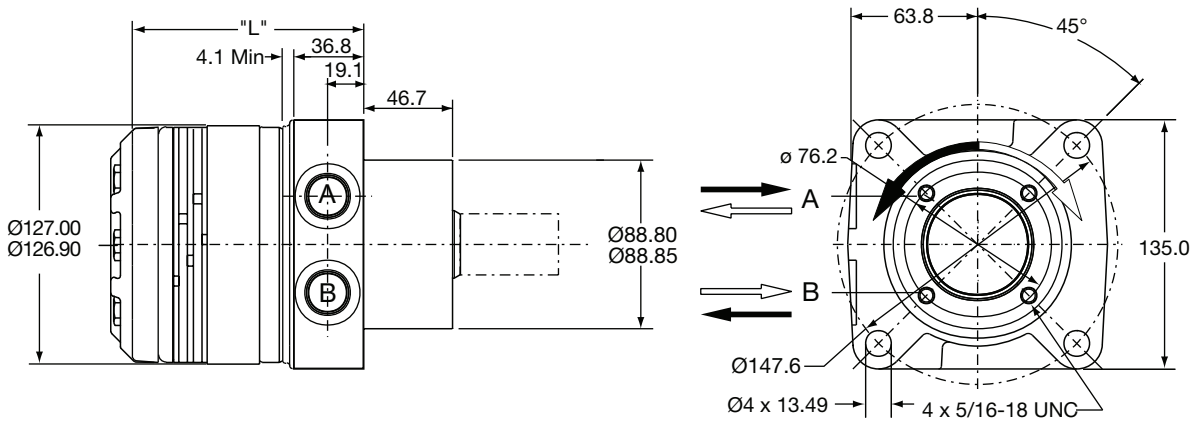

Code L

Gewicht / Weight	TL0140	TL0170	TL0195	TL0240	TL0280	TL0310	TL0360
Poids / Peso [kg]	10.9	11.1	11.4	11.8	12.2	12.4	12.9
Length "L" [mm]	124	124	124	127	132	135	143

Code: U

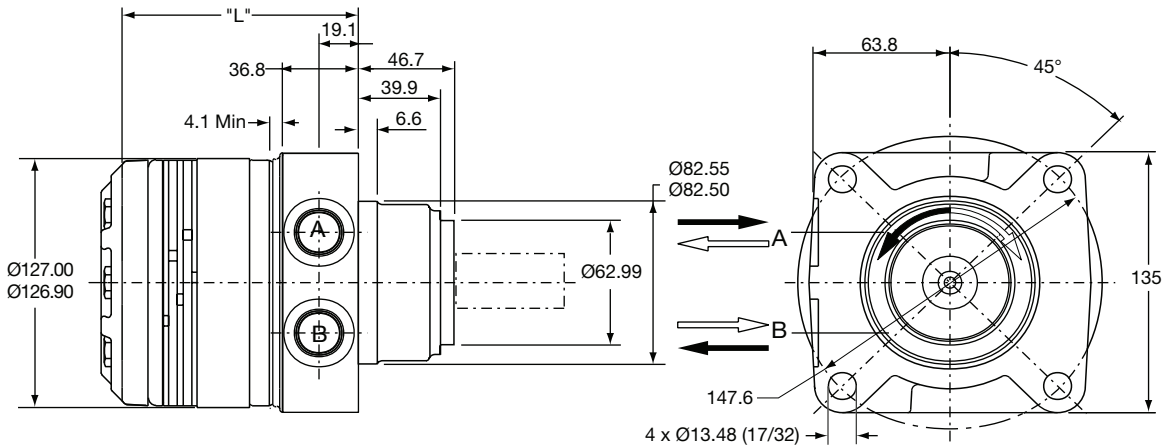

Code U

Gewicht / Weight	TL0140	TL0170	TL0195	TL0240	TL0280	TL0310	TL0360
Poids / Peso [kg]	10.9	11.1	11.4	11.8	12.2	12.4	12.9
Length "L" [mm]	124	124	124	127	132	135	143

Code: S

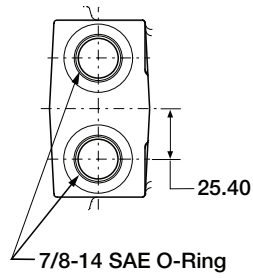

**Shafts / Abtriebswellen
 Arbre / Ejes**

Code: L, U

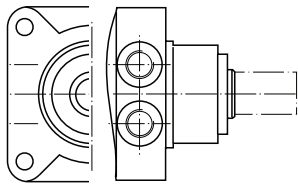

Code: 08

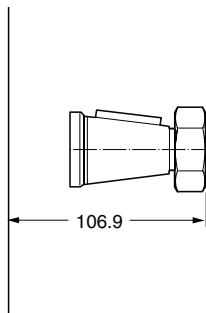

Code: 08

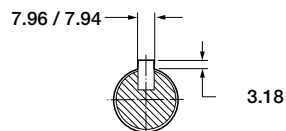
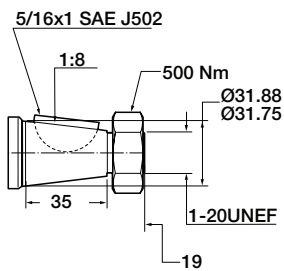

TL 140

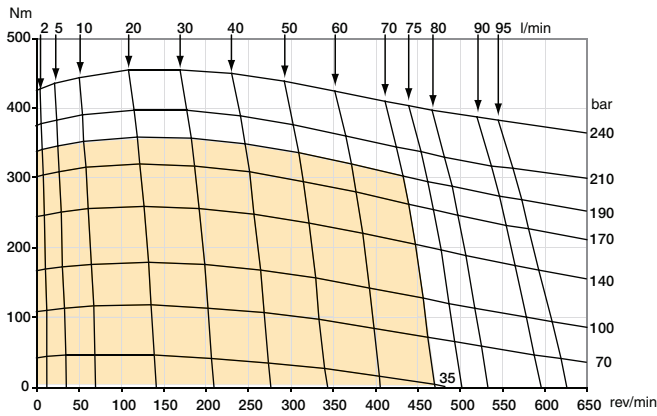

TL 169

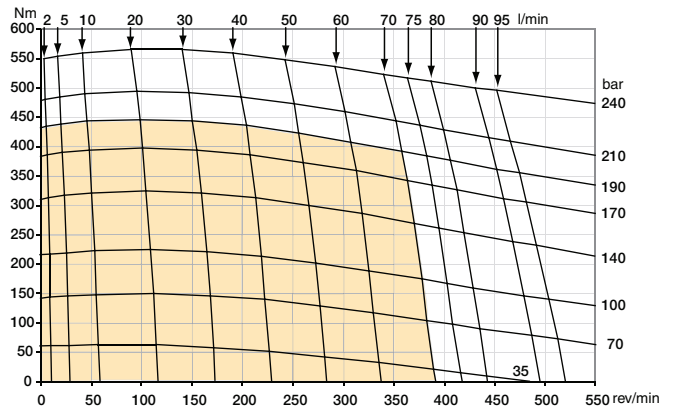

TL 195

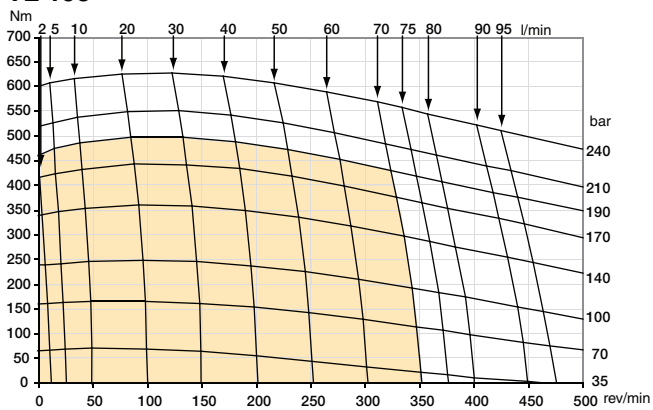

TL 238

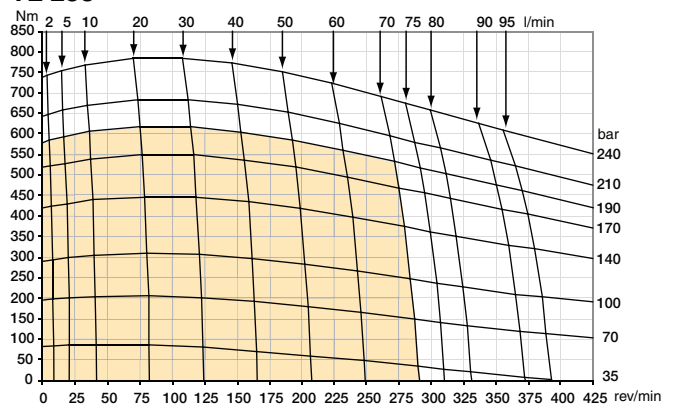

TL 280

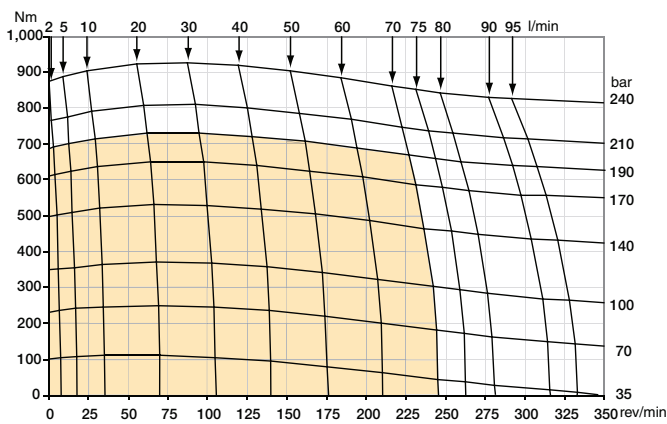

TL 310

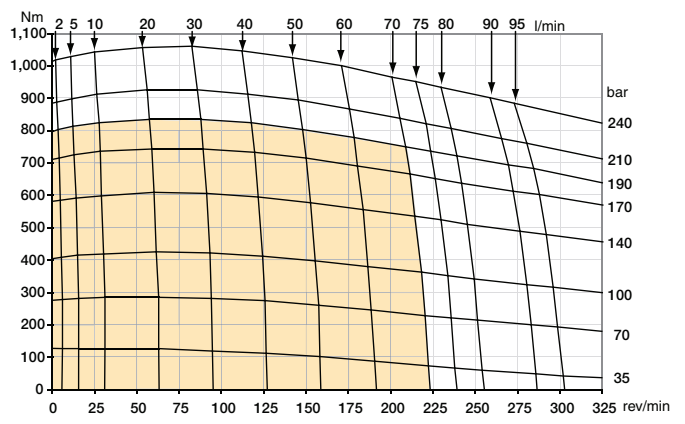

TL 334

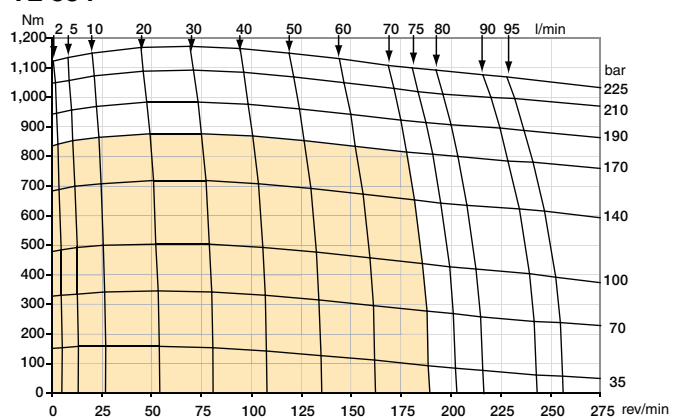

■ Cont. □ Int.

int. =
 Intermittierende Werte maximal: 10% von jeder Betriebsminute.
 Intermittent operation rating applies to 10% of every minute.
 Fonctionnement interm.: 10% max. de chaque minute d'utilisation.
 Servizio intermittente: 10% max di ogni minuto di utilizzazione.

Wheel Mount / Radnabengehäuse

Monture à roue/ Montaje de rueda

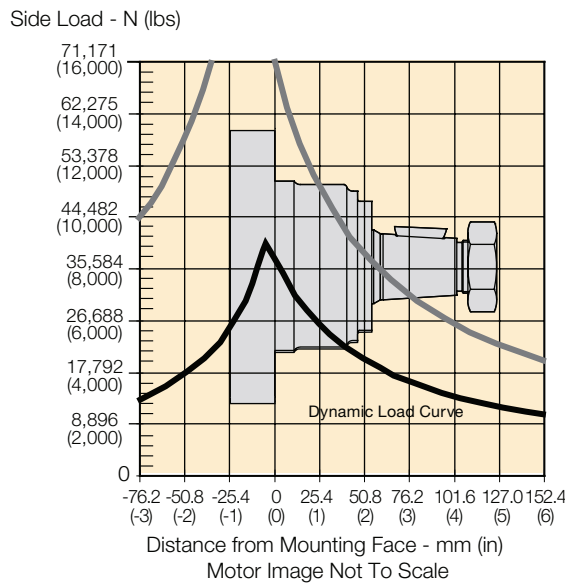

The dynamic side load curve is based on uni-directional steady state loads for L₁₀ bearing life at 3 x 10⁶ revolutions.

Die zulässige auslegbare radiale Wellenbelastungskurve ist unter ruhenden, einseitig statisch gerichteten Lastverhältnissen auf eine L₁₀ Lebensdauer mit 3 x 10⁶ Umdrehungen kalkuliert.
 La courbe de charge latérale permise se base sur des charges unidirectionnelles en régime permanent pour le roulement L₁₀ à 3 x 10⁶ révolutions.
 La curva de valores admisibles de carga lateral está basada en cargas constantes para cojinetes L₁₀ a 3 x 10⁶ revoluciones.

The maximum load curve is defined by bearing static load capacity. This curve should not be exceeded at any time including shock loads.

Die maximale radiale Wellenbelastungskurve ist definiert als maximale statische Last ohne Drehzahl. Sie gilt als Grenze und sollte keinesfalls überschritten werden.
 La courbe de charge maximale est définie par la capacité de charge statique portante. Cette courbe ne devrait être dépassée en aucun moment y compris pour les charges par à-coups.
 La curva de carga máxima queda definida por la capacidad de carga estática del cojinete. No se deben superar los valores de esta curva, ni siquiera con cargas provisorias de impacto.

**Equation to Calculate the Expected Radial Bearing Life
 Gleichung zur Ermittlung der Lagerlebensdauer**

Equation to calculate the dynamic bearing life for a given load:
 Bestimmung der erlaubten radialen Wellenbelastung mit vorgegebener Last

Use F_a, F_b and S in equation to determine hours of L₁₀ bearing life.
 Die Lebensdauer in Stunden ergibt sich durch einsetzen von F_a, F_b, und S in die nachstehende Formel.

$$L = \frac{3 \times 10^6}{60 \times S} \left\{ \frac{F_a}{F_b} \right\}^{3.33}$$

Where / Mit:

- S = Shaft Speed RPM / Abtriebswellendrehzahl in min⁻¹
- L = Life In Hours / Lebensdauer in Stunden
- F_a = Dynamic side load defined by above curve at a distance from mounting flange. / Erlaubte radiale Wellenbelastung als Function der Laenge
- F_b = Application side load. / Anwendungsseitige Wellenbelastung

Torqmotor Series TL

Ordering Code

TL

Serie
Series
Série
Serie

Schluckvolumen
Displacement
Cylindrée
Cilindrata

Gehäuse
Housing
Carter
Corpo motore



Anschluss
Ports
Plan de raccordement
Conessioni

Welle
Shaft
Arbre
Albero

Drehrichtung
Direction of rotation
Direction de rotation
Direzione di rotazione

Option
code

Code	cm ³ /rev	In ³ /rev
0140	141	8.6
0170	169	10.3
0195	195	11.9
0240	238	14.5
0280	280	17.1
0310	310	18.9
0360	364	22.2

Code	Housing
L	wheel, Front Brake Nose 
U	Wheel, Standard 

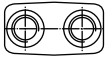
Code	Front port
S	7/8-14 SAE 

Code	Shaft
08	1 1/4" Tapered 

Code	Rear port
AAAB	No Paint No lackiert
AAAA	Black Paint Schwarz lackiert

Code	Front Port Rotation
0	Standard 
1	Reverse Timed Manifold 