

Tolerance values given in the specification is subject to internal regulation TEDOM: 61-0-0284.

Description:

Engine type	TG 110 G5V TX 86 (Dwg. No. 7000 850/xx)	
Fuel	natural gas (according to TEDOM: 61-0-0282.1 regulation)	
Engine design	stationary	
Engine working cycle	four-stroke, spark ignited	
Design	in-line, vertical	
Number of cylinder	6	
Valve train	OHV	
Number of valves per cylinder	2	
Turbocharging	yes	
Intercooler	no	
Mixture	lean	
Cooling	liquid	
Operation (looking at flywheel)	anticlockwise	
Displacement	11,946	[dm ³]
Bore	130	[mm]
Stroke	150	[mm]
Compression ratio	12:1	[-]
Firing order	1-5-3-6-2-4	[-]

Rated parameters at reference conditions:

Rated speed	1500	[rpm]
Rated power output (continuous)	110,4	[kW]
Peak torque	703	[Nm]

Engine heat output:

Coolant heat output	67,6	[kW]
Exhaust gas heat output (cooled to 120 °C)	75,2	[kW]
Radiation heat power	11,5	[kW]

Parameters under load:

Load	100	75	50	25	[%]
Fuel input power	282,8	224,5	167,5	111,2	[kW]
Efficiency	39,0	36,9	33,0	24,8	[%]
Fuel consumption	29,9	23,8	17,7	11,8	[m ³ .h ⁻¹]

Load Characteristics:

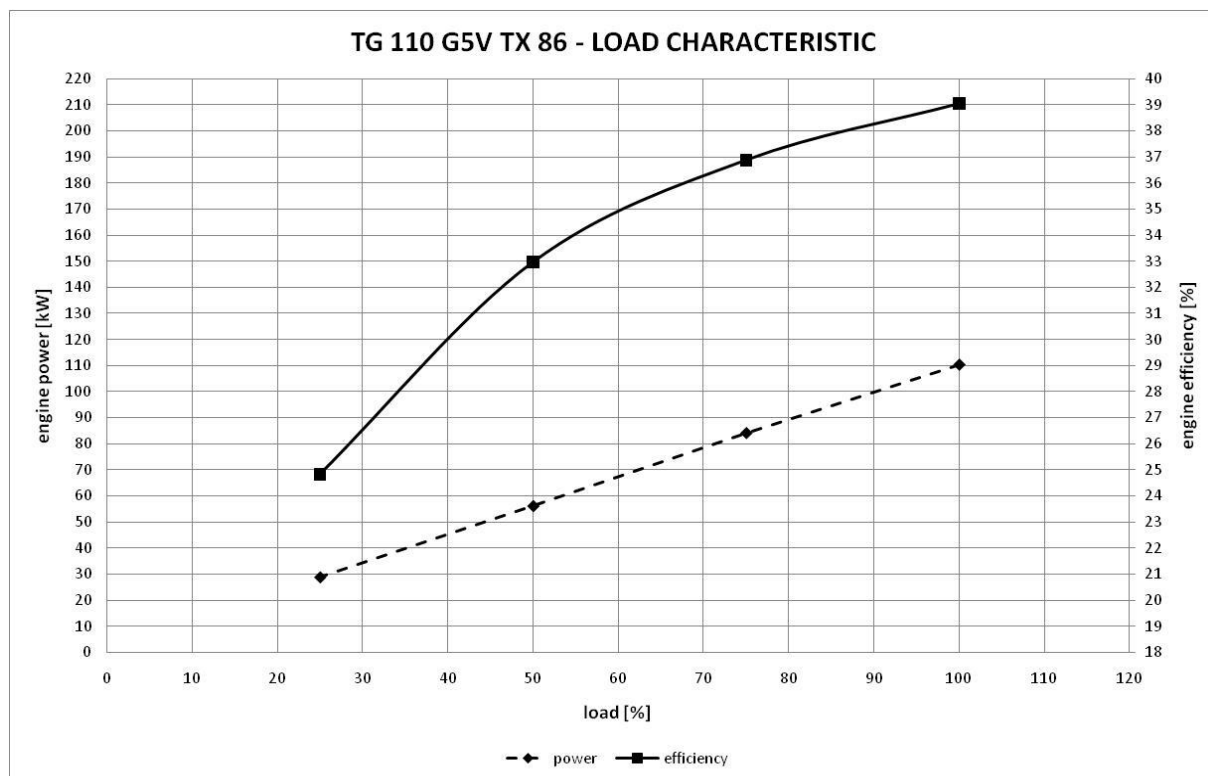

Engine parameters and settings:

Ignition advance	35	[°]
Coefficient of excess air λ	1,642	[-]
Exhaust gas temperature at the inlet to the turbocharger	556	[°C]
Exhaust gas temperature at the outlet from the turbocharger	513	[°C]
Combustion air flow	607	[kg.h ⁻¹]
Exhaust gas flow	638	[kg.h ⁻¹]
Max. exhaust back pressure for rated parameters (at output of the turbocharger)	3,5	[kPa]
Recommended exhaust gas temperature for warning signal (before turbocharger)	580	[°C]
Recommended exhaust gas temperature for stop signal (before turbocharger)	600	[°C]

Technical and build-up parameters:

REGIME OF THE ENGINE REVOLUTION		
Overrun speed max. - gas cut-off	2100	[rpm]
Overrun speed max. - ignition deactivation	2100	[rpm]
ENGINE LUBRICATION		
Lubricating oil - total	56	[dm ³]
Lubricating oil - oil sump - max. mark	51	[dm ³]
Lubricating oil - between max. and min.	8	[dm ³]
Oil consumption	0,3-0,5	[g.kW ⁻¹ .h ⁻¹]
Min. operating oil pressure - rated speed (see Instruction handbook)	360	[kPag]
ENGINE COOLING		
Volume of coolant in engine	22	[dm ³]
Coolant temperature at the outlet from the engine	85-95	[°C]
Max. coolant temperature short time (1 hour)	100	[°C]
Min. coolant temperature for 100 % load	60	[°C]
Maximum load for the coolant temperature below 60 °C	25	[%]
Minimum coolant temperature for start	10	[°C]
Recommended power cooler	150	[kW]
Required engine coolant flow	250-300	[dm ³ .min ⁻¹]
Maximum cooling circuit pressure	260	[kPaa]
OPERATING LIMITATIONS		
Min. intake air temperature for start	10	[°C]
Intake air (mixture) temperature input before turbocharger for the nominal parameters	25	[°C]
Maximum temperature of the engine compartment during operation	80	[°C]
Allowed crankcase pressure range	-2/+1	[kPa]
OPERATING CLEARANCE		
Cold valve clearance - intake valve	0,35	[mm]
Cold valve clearance - exhaust valve	0,55	[mm]

Emissions:

Nitrogen oxides - NO _x	< 500	[mg.m _n ⁻³]
Carbon monoxide - CO	< 650	[mg.m _n ⁻³]
Total hydrocarbons - HC	-	[mg.m _n ⁻³]
Particulate - PM ^b	-	[mg.m _n ⁻³]
Formaldehyde - HCHO	< 60	[mg.m _n ⁻³]
with catalyst KTD 8024-3	< 20	[mg.m _n ⁻³]

Engine noise - 100% load:

Sound power level of the engine at a distance of 1 m	93,2	[dB(A)]
Sound power level of the exhaust line noise at a distance of 1 m	109	[dB(A)]

Head loss engine block:

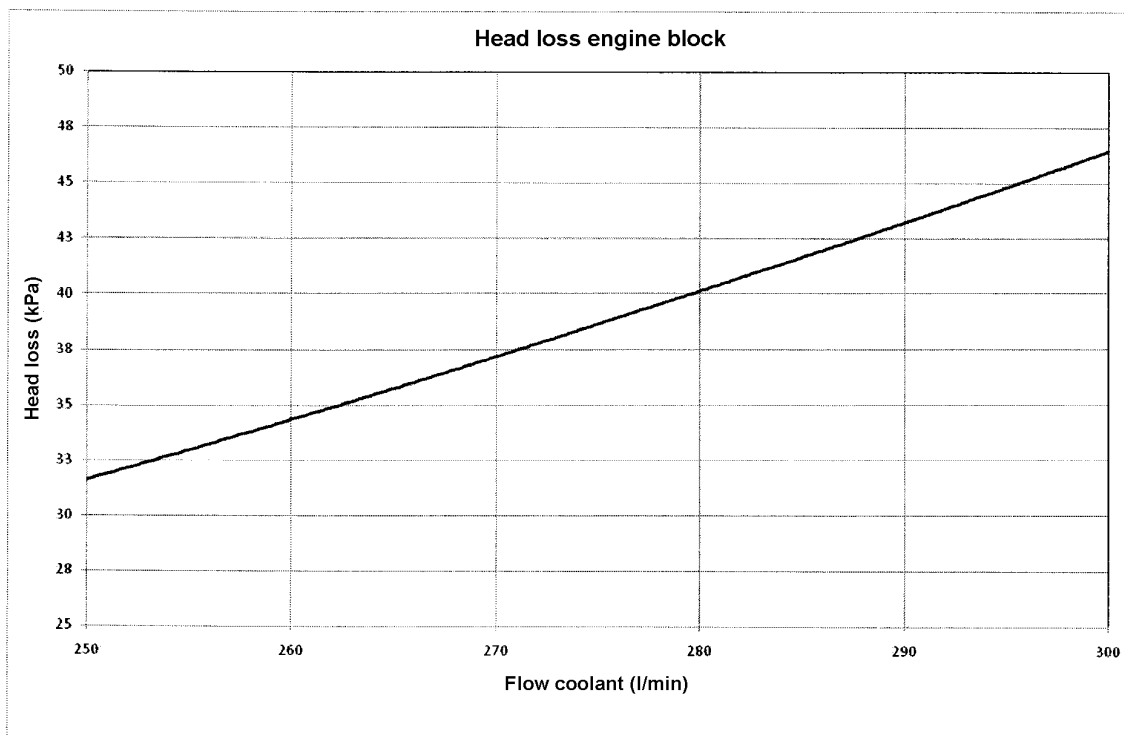

Reference ambient conditions:

Barometric pressure	100	[kPa]
Ambient temperature	25	[°C]
Relative air humidity	30	[%]

Fuel characteristic:

Fuel pressure - reference	101,325	[kPa]
Fuel temperature - reference	15	[°C]
Fuel relative humidity	0	[%]
LHV	34	[MJ.m ⁻³]
CH ₄ concentration (biogas engines)	-	[%]
CO ₂ concentration (biogas engines)	-	[%]

Allowed fuel characteristic:

Fuel efficiency (biogas engines)	-	[MJ.m ⁻³]
Minimum CH ₄ concentration	80	[%]
Minimum methane number fuel	80	[-]

Correction of power depending on the altitude:

Altitude	500	750	1000	1250	1500	[m a.s.l.]
Correction factor	1	0,95	0,90	0,86	0,81	[-]

Correction of power depending on the temperature of inlet air:

Inlet air temperature	0	5	10	15	20	25	30	35	40	45	50	[°C]
Correction factor	1,18	1,14	1,11	1,07	1,04	1	0,96	0,93	0,89	0,86	0,82	[-]

Time limits for low load operation:

Engine power [%]	Runtime [min]
0 – 30	30*
31 - 50	120*
51 - 100	Continuous

* After allowed running time under 51 % of nominal power must follow min. 2 hours recovery run above 70 % of nominal engine power.

Other operating restrictions:

- Up to 4 Start per day are possible
- Minimum runtime 1 hour per Start
- Due to wear 1 start is equal 0,5 operating hours

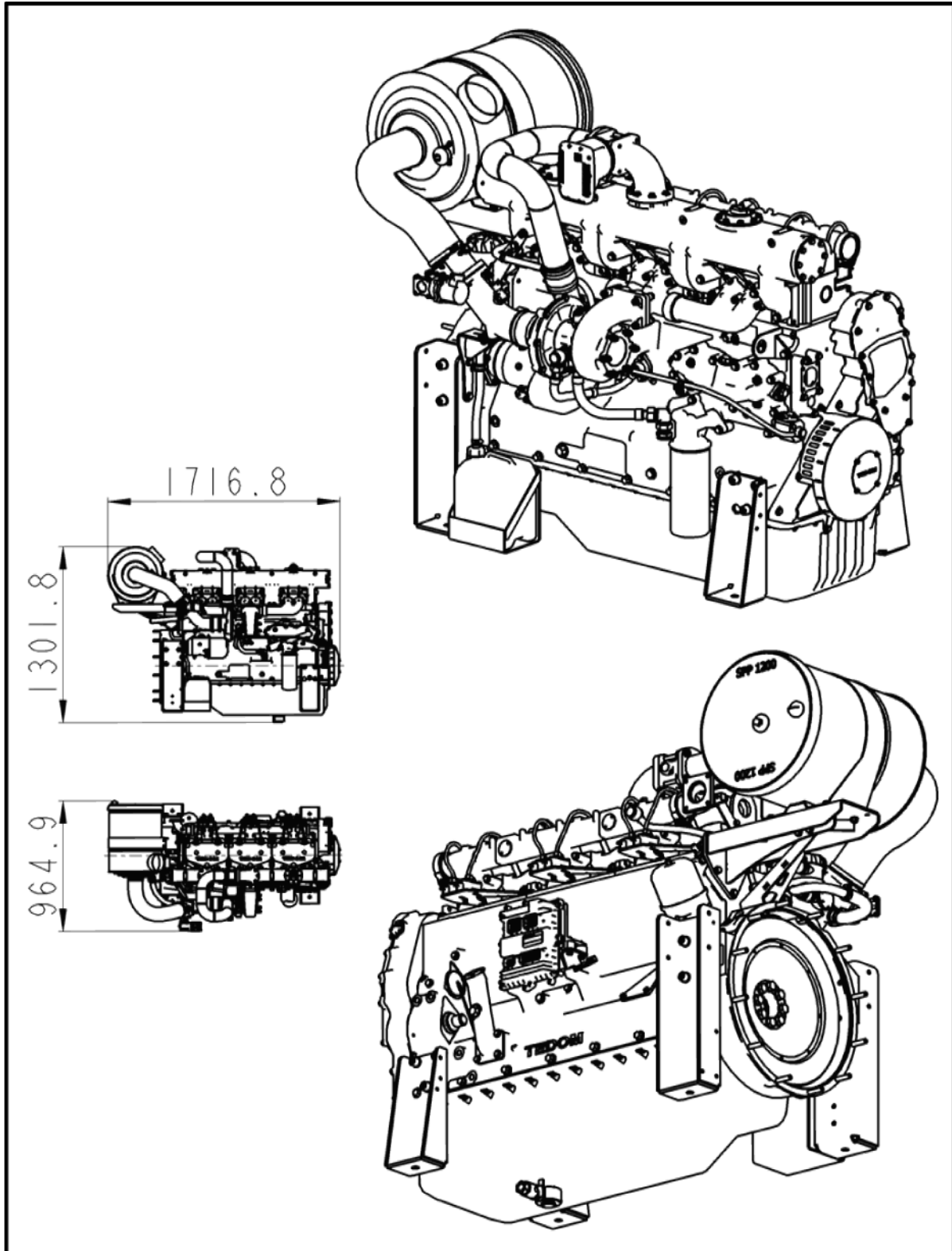
Outline dimensions of the engine:

Total engine weight:

Total engine weight	950	[kg]
---------------------	-----	------

Fitting dimensions of the engine:

Flywheel housing	SAE 1 (alternator)
Engine block/ flywheel housing	SAE 1 (with rear brackets)
Engine block	4 x M16 (for front brackets)
Flywheel	SAE 11½ (or SAE 14)

Publication specification:

Date of specification:	Specification version:	Elaborated by:	Note:
6.10.2011	1st. edition	T. Hampl	
9.2.2012	REVISION A	T. Hampl	pT2 = CHP
28.5.2012	REVISION B	T. Hampl	3 at 5
10.1.2013	REVISION C	V. Gulova	Emissions (Formaldehyde) engine with catalyst
16.9.2013	REVISION D	V. Gulova	Changing the ignition advance from 31° to 35°
5.12.2014	REVISION E	V. Gulová	Revision No. 558/14
9.2.2015	REVISION F	T. Hampl	Engine noise
1.11.2016	REVISION G	V. Gulova	Allowed crankcase pressure range
9.1.2018	REVISION H	V. Gulova	Cold valve clearance - intake valve
28.3.2019	REVISION I	V. Gulova	Revision No. 520/19
29.4.2020	REVISION J	V. Gulova	Revision No. 534/20